



Hygiene

Hygiene

The maintenance of a clean and safe evaporative cooler is achieved by the following:

- Avoidance of stagnant water
- Low water operating temperature
- Avoidance of corrosion and scaling
- Use of a biocide
- No production of aerosols
- Maintenance

Avoidance of stagnant water: Since no dead legs exist in the system no stagnation occurs during normal operation of an EcoCooling cooler. When a unit is switched off the system automatically drains.

Low water operating temperature: The temperature of the water circulating in the evaporative cooler is approximately the “wet bulb temperature” of the air passing over the filters. In practice this means that, in a temperate climate, the water temperature rarely goes above 20°C as shown even when the air on temperature exceeds 35°C

It is generally accepted that Legionella is not a risk with water temperatures less than 20°C

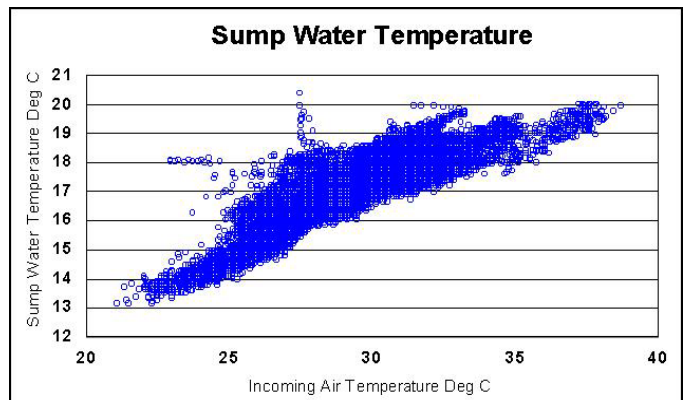

Avoidance of corrosion and scaling: To prevent corrosion all water contact surfaces are plastic. The EcoCooling cooler measures the quantity of water fed to the machine. When a concentration factor is reached the sump empties automatically and replenishes with fresh water. This has the effect of preventing scale and removing contaminants filtered from the air.

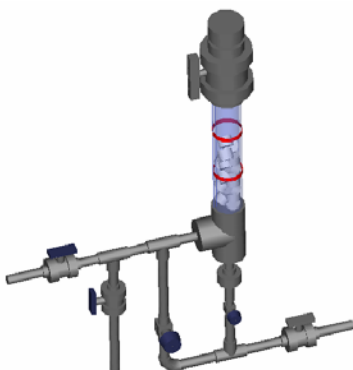

Use of Biocide (optional): Growth of organisms filtered from the air is suppressed by supplying the evaporative cooler with water with a low level of biocide.

No production of aerosols: The design of EcoCooling coolers is such that only pure water evaporation without any production of droplets occurs as the air passes over the filters. This removes the mechanism for the transmission of infections such as Legionnaires' disease.

Maintenance: By the implementation of a programmed maintenance system, the standards of hygiene are continued to provide a safe and secure system.